



Project Name: _____

Item #: _____

Quantity: _____

Type: Blast Chiller/Shock Freezer (Self-Contained)
Model: AP7BCF70-2-C-P



Blast Chiller/Shock Freezer (Self-Contained) - AP7BCF70-2-C-P

Standard Features

PERFORMANCE:

- Blast chilling (soft or hard) lowers the food core temperature from 160°F to 38°F within 90 minutes.
- Shock freezing lowers the food core temperature from 160°F to 0°F within 4 hours.
- *Chilling times will vary somewhat, depending on the food quantity, initial temperature, density, moisture content, specific heat, and type of container.*
- The airflow has a high velocity, indirect pattern designed to cool all levels at identical rates.
- Time/temperature chilling rates meet or exceed all FDA, NSF, and state regulations.

TOUCHSCREEN CONTROLS:

- 7" glove-safe capacitive touchscreen
- Easily readable from across the kitchen
- User friendly interface and quick access to all functions
- Quick-start button for one touch operation
- Capable of automated defrost and sanitation cycles
- HACCP logger, data download via optional Wifi card or USB port
- Available cycles - Soft Chill, Hard Chill, Shock Freeze, Quick Start
- One core temperature probe is provided

CABINET CONSTRUCTION:

- Constructed of polished type 304 stainless steel.
- Cabinet is a 36" high countertop with backsplash
- 2" of CFC-free, high density polyurethane insulation.
- Interior has a mirror finish and fully rounded interior bottom
- 7 wire racks provided
- Removable magnetic door gasket.
- Door is hinged on the operator's left
- 6' long four wire cord set with NEMA 6-15P plug provided
- 6" height adjustable legs (adjustable up to 9" high)
- Clearance: 32" at the front for door opening, 5" at the back, and 3" either side

REFRIGERATION SYSTEM:

- Self-contained refrigeration system
- E-coated (electro-deposition coated) multiple circuits evaporator designed specifically for blast chilling operation
- Wash-down type motorized impeller fans with sealed ball bearing and overload protection
- Hinged swing out vent panel for easy evaporator cleaning
- Condensing unit uses R290 refrigerant



Overview: American Panel's blast chillers and shock freezers are the perfect product for all of your chilling and freezing needs. These units are completely self contained and ready for plug and play operation. The HURRICHILL series of chillers also features a consolidated evaporator fan assembly. This places all of the components within the cabinet, which greatly reduces the overall footprint of the unit. American Panel quality and precision in a flexible format to fit your needs.

Capacity

- (7) 12"x20"x2.5" pans
- (7) 18"x26" sheet pans

Product Yield

- 70 lbs. - 160°F - 38°F in 90 minutes
- 70 lbs. - 160°F - 0°F in 240 minutes

Warranty

3 year parts & labor standard warranty.
Warranty excludes food probes.
The compressor only is covered for an additional period of two years, as a part only, no labor.



Certifications



Type: Blast Chiller/Shock Freezer (Self-Contained)

Model: AP7BCF70-2-C-P



Dimensions

INSTALLATION: A detailed installation manual is provided. It must be carefully followed to ensure proper operation and to protect your rights under the warranty.

Model	H	W	D	Eq. Weight	Ship Weight
AP7BCF70-2-C-P	44	56 1/16	33 7/8	416 lbs.	750 lbs.

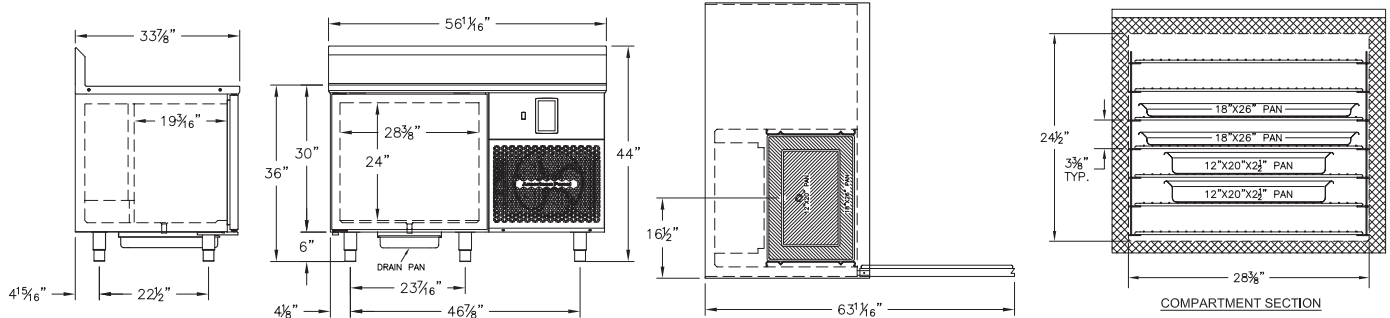

Utility Specifications

Model	Electrical							Heat of Rejection BTU/HR	Refrigeration System			
	V	Hz	PH	A	MCA	MOPD	PLUG		Compressor HP	Ref	Charge Amount	BTU/HR* Capacity
AP7BCF70-2-C-P	208	60	1	5.7	20	20	6-15P	12,000	1.5	R290	5.29 oz	11,690

* - Rating at 14°F SST and 105°F cond. temp.

Controller



Soft Chilling: The air temperature is held in the range of 28°F to 35°F, the cycle is completed when the food core temperature reaches 38°F.

Hard Chilling: The air temperature is lowered to and held within a range of 10°F to 20°F. When the food core temperature reaches 60°F, the air temperature rises to a range of 28°F to 35°F. The chilling cycle is completed when the food core temperature reaches 38°F.

Shock Freeze: The air temperature is lowered to and held within a range of -25°F and -15°F. The freezing cycle is completed when the food core temperature reaches 0°F.

Quick Start: Programmable single touch button to start a cycle.

ADDITIONAL FUNCTIONS:

Holding: At the end of any cycle, the unit will automatically switch to a holding mode.

Defrost: A heated defrost cycle is included.

Options and Accessories

- Cabinet Sanitation:** The automated sanitation cycle and odor control system keeps the chiller fresh and free of contamination. The patented technology creates PhotoPlasma® by recirculating air inside the blast chiller over a UV light. This PhotoPlasma® treats the air and surfaces inside the blast chiller to neutralize odors at their sources and to inhibit the growth of contamination. The system is not intended to sanitize food.
- USB HACCP Interface:** Use a standard USB thumb drive to easily download HACCP data. The information recorded includes date, time, cycle identification, recipe name, and product core temperature at prescribed intervals.
- Wi-Fi Connectivity:** Supported functions include peer-to-peer connectivity, remote monitoring over the local network, HACCP data download and alarm notifications via e-mail.
- Extra Food Probes:** One probe is standard, up to three additional probes can be provided.
- Heavy duty casters,** two with brakes, 3" (4.25" ride height), 4" (5.25" ride height) or 5" (6.25 ride height).
- Thaw Package:** to include a thaw probe, sanitary bit, and a battery operated drill (automatic thawing requires probing the frozen product).
- Probe support for liquids:** The probe support will clip onto the edge of a standard steam table pan.
- Drain line assembly:** As standard the unit is provided with a drain pan that needs to be emptied daily. The drain line assembly will make it easy to hook up the unit to a floor sink.
- No Backsplash Countertop:** Stainless steel countertop with no backsplash.

Blast Chiller/Shock Freezer (Self-Contained) - AP7BCF70-2-C-P