



Project Name: _____

Item #: _____

Quantity: _____

Type: Blast Chiller/Shock Freezer (Roll-in Remote)
Model: AP24BCF300-3



Blast Chiller/Shock Freezer (Roll-in Remote) - AP24BCF300-3

Standard Features

PERFORMANCE:

- Blast chilling (soft or hard) lowers the food core temperature from 160°F to 38°F within 90 minutes.
- Shock freezing lowers the food core temperature from 160°F to 0°F within 4 hours.
- *Chilling times will vary somewhat, depending on the food quantity, initial temperature, density, moisture content, specific heat, and type of container.*
- The airflow has a high velocity, indirect pattern designed to cool all levels at identical rates.
- Time/temperature chilling rates meet or exceed all FDA, NSF, and state regulations.

TOUCHSCREEN CONTROLS:

- 7" glove-safe capacitive touchscreen
- Easily readable from across the kitchen
- User friendly interface and quick access to all functions
- Quick-start button for one touch operation
- Capable of automated defrost and sanitation cycles
- HACCP logger, data download via optional Wifi card or USB port
- Available cycles - Soft Chill, Hard Chill, Shock Freeze, Quick Start
- One core temperature probe is provided

CABINET CONSTRUCTION:

- Constructed of polished type 304 stainless steel,
- 2 3/4" of CFC-free, high density polyurethane insulation.
- Fully rounded interior bottom
- Removable magnetic door gasket.
- Door is hinged on the operator's left
- Integral 2" long ramp for roll-in operation
- Clearance: 15" at the top cabinet for service. 36" at the front for door opening. 4" on either side for door opening and service.

REFRIGERATION SYSTEM:

- Refrigeration system is complete with all components including controls, evaporator, TXV and solenoid valves, and blower system
- E-coated (electro-deposition coated) multiple circuits evaporator designed specifically for blast chilling operation
- Wash-down type motorized impeller fans with sealed ball bearing and overload protection
- Hinged swing out vent panel for easy evaporator cleaning



Overview: American Panel's HURRiCHILL series of blast chillers and shock freezers are the perfect product for all of your chilling and freezing needs. The HURRiCHILL series of chillers also features a consolidated evaporator fan assembly. This places all of the components within the cabinet, which greatly reduces the overall footprint of the unit. American Panel quality and precision in a flexible format to fit your needs.

Capacity

One mobile rack (not included), maximum dimensions of 30"W x 36.25"D x 73.5"H.

Product Yield

300 lbs. - 160°F - 38°F in 90 minutes

360 lbs. - 160°F - 38°F in 120 minutes

180 lbs. - 160°F - 0°F in 240 minutes

Warranty - Chiller & Doors

1 year parts & labor standard on chiller & doors only.
Warranty excludes food probes.
For remote refrigeration warranty, see Options & Accessories

Certifications



Controller



Soft Chilling: The air temperature is held in the range of 28°F to 35°F, ideal for delicate food items. The chilling cycle is completed when the food core temperature reaches 38°F.

Hard Chilling: The air temperature is lowered to and held within a range of 0°F to 10°F. When the food core temperature reaches 60°F, the air temperature rises to a range of 28°F to 35°F. The chilling cycle is completed when the food core temperature reaches 38°F.

Shock Freeze: The air temperature is lowered to and held within a range of -25°F and -15°F. The freezing cycle is completed when the food core temperature reaches 0°F.

Quick Start: Programmable single touch button to start a cycle. Used for the most popular settings for the customer. This allows for starting any chilling or freezing cycle with one touch..

ADDITIONAL FEATURES:

Thawing (Optional): Not available on AP24BCF300-3

Holding: At the end of any cycle, the unit will automatically switch to a holding mode which will keep the food at holding temperature until the cycle is stopped.

Defrost: Air defrost cycle is included within the unit's controller programming.

Product Names: Store up to 150 product names.

Dimensions

INSTALLATION: A detailed installation manual is provided. It must be carefully followed to ensure proper operation and to protect your rights under the warranty.

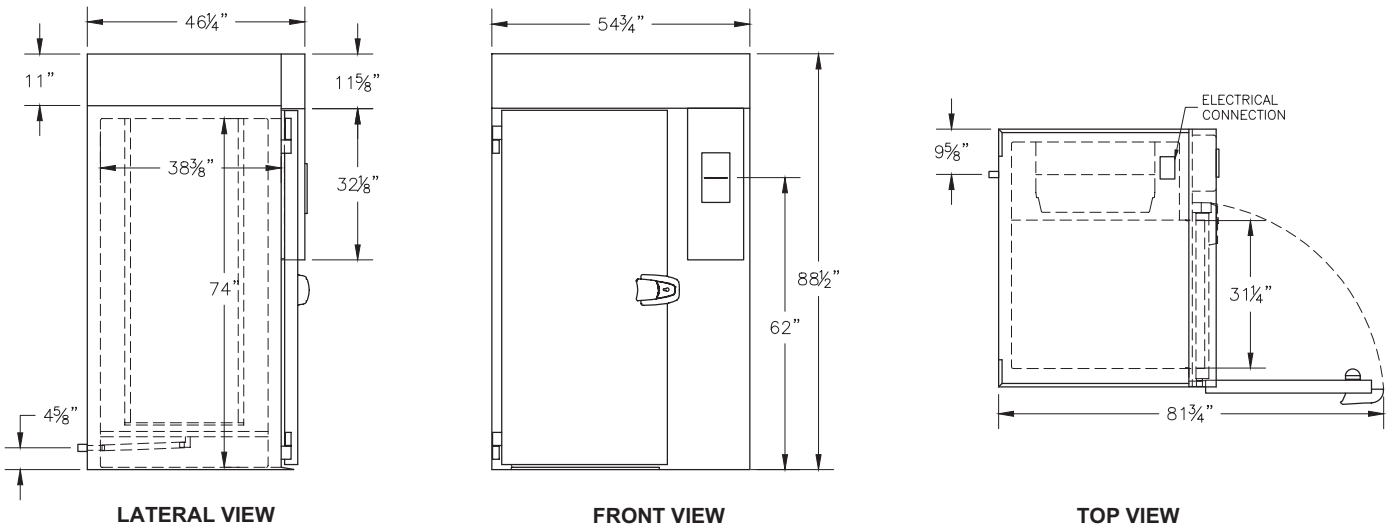

Specifications

Model	Electrical						Refrigeration Connections		Required Condensing Unit			Ship Weight
	V	Hz	PH	A	MCA	MOPD	Liquid Line	Suction Line	Type	Ref	BTU/HR*	lbs.
AP24BCF300-3	208	60	3	8	15	15	5/8"	1 3/8"	Med.Temp. 40°F - -40°F	R404A	50,000	1240

* - Rating at 14°F SST and 105°F cond. temp.

Options and Accessories

- Cabinet Sanitation:** The ozone and PhotoPlasma generator sanitizes all metal surfaces within the cabinet in a preset time of 30 minutes.
- USB HACCP Interface:** Use a standard USB thumb drive to easily download HACCP data. The information recorded includes date, time, cycle identification, recipe name, and product core temperature at prescribed intervals.
- Wi-Fi Connectivity:** Supported functions include peer-to-peer connectivity, remote monitoring over the local network, HACCP data download and alarm notifications via e-mail.
- Remote Refrigeration:** RCU7BCF, available in air cooled and water cooled configuration (5 year compressor, 1 year parts warranty provided).
- Extra Food Probes:** One probe is standard, up to three additional food probes can be provided.
- Mobile Racks:** Model APR13-26 will accommodate 26 full size steam table pans (12"x20"x2 1/2") or 13 full size sheet pans (18"x26").
- Probe holder for liquids:** The probe support will clip onto the edge of a standard steam table pan.
- Bumper Rail:** 2" wide bumper rail mounted on either side of the unit. the center line of the bumper rail will be located at 36" AFF.
- Alternate refrigerant configuration available**
- Reverse cabinet (RHH)**