



Project Name: _____

Item #: _____

Quantity: _____

Type: Blast Chiller (Roll-in Remote)
Model: AP24BC250-3



Blast Chiller (Roll-in Remote) - AP24BC250-3

Standard Features

PERFORMANCE:

- Blast chilling (soft or hard) lowers the food core temperature from 160°F to 38°F within 90 minutes.
- Chilling times will vary somewhat, depending on the food quantity, initial temperature, density, moisture content, specific heat, and type of container.
- The airflow has a high velocity, indirect pattern designed to cool all levels at identical rates.
- Time/temperature chilling rates meet or exceed all FDA, NSF, and state regulations.

TOUCHSCREEN CONTROLS:

- 7" glove-safe capacitive touchscreen
- Easily readable from across the kitchen
- User friendly interface and quick access to all functions
- Quick-start button for one touch operation
- Capable of automated defrost and sanitation cycles
- HACCP logger, data download via optional Wifi card or USB port
- Available cycles - Soft Chill, Hard Chill, Quick Start
- One core temperature probe is provided

CABINET CONSTRUCTION:

- Constructed of polished type 304 stainless steel,
- 2 3/4" of CFC-free, high density polyurethane insulation.
- Fully rounded interior bottom
- Removable magnetic door gasket.
- Door is hinged on the operator's left
- Integral 2" long ramp for roll-in operation
- Clearance: 15" at the top cabinet for service. 36" at the front for door opening. 4" on either side for door opening and service

REFRIGERATION SYSTEM:

- Refrigeration system is complete with all components including controls, evaporator, TXV and solenoid valves, and blower system
- E-coated (electro-deposition coated) multiple circuits evaporator designed specifically for blast chilling operation
- Wash-down type motorized impeller fans with sealed ball bearing and overload protection
- Hinged swing out vent panel for easy evaporator cleaning



Overview: American Panel's HURRICHILL series of blast chillers and shock freezers are the perfect product for all of your chilling and freezing needs. The HURRICHILL series of chillers also features a consolidated evaporator fan assembly. This places all of the components within the cabinet, which greatly reduces the overall footprint of the unit. American Panel quality and precision in a flexible format to fit your needs.

Capacity

One mobile rack (not included), maximum dimensions of 30"W x 36.25"D x 73.5"H.

Product Yield

- 250 lbs. - 160°F - 38°F in 90 minutes
- 288 lbs. - 160°F - 38°F in 120 minutes

Warranty

3 year parts & labor standard warranty.
Warranty excludes food probes.
The compressor only is covered for an additional period of two years, as a part only, no labor.



Certifications



Type: Blast Chiller (Roll-in Remote)

Model: AP24BC250-3



Dimensions

INSTALLATION: A detailed installation manual is provided. It must be carefully followed to ensure proper operation and to protect your rights under the warranty.

Model	H	W	D	Eq. Weight	Ship Weight
AP24BC250-3	88 1/2"	54 3/4"	46 1/4"	704 lbs.	1,240 lbs.

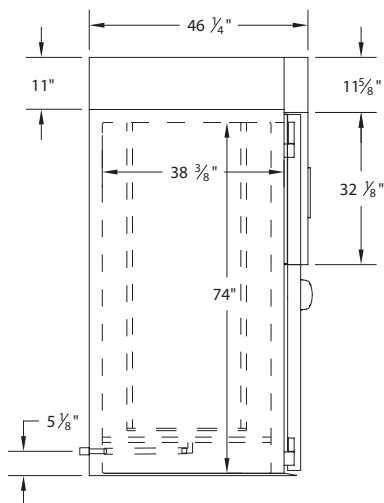

LATERAL VIEW

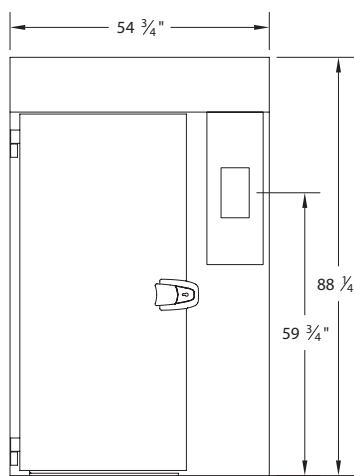

FRONT VIEW

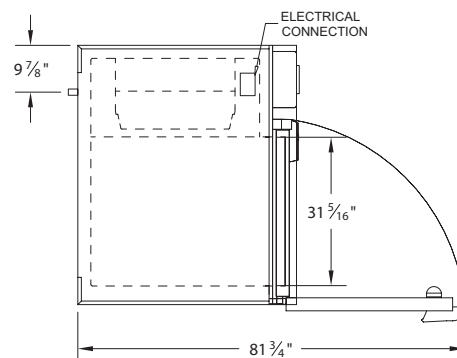

TOP VIEW

Utility Specifications

Model	Electrical							Refrigeration Connections		Required Condensing Unit		
	V	Hz	PH	A	MCA	MOPD	Plug	Liquid Line	Suction Line	Type	Ref	BTU/HR*
AP24BC250-3	208	60	3	8	15	15	Direct	5/8"	1 3/8"	Med.Temp. 40°F - -10°F	R448A	25,000

* - Rating at 14°F SST and 105°F cond. temp.

Controller

Soft Chill
FOR DELICATE ITEMS

Hard Chill
FOR HEAVY ITEMS AND PROTEINS

Shock Freeze
QUICKLY FREEZE FOOD PRODUCTS

Quick Start
HARD CHILL | MANUAL MODE

Soft Chilling: The air temperature is held in the range of 28°F to 35°F, the cycle is completed when the food core temperature reaches 38°F.

Hard Chilling: The air temperature is lowered to and held within a range of 10°F to 20°F. When the food core temperature reaches 60°F, the air temperature rises to a range of 28°F to 35°F. The chilling cycle is completed when the food core temperature reaches 38°F.

Shock Freeze: Not available on the AP24BC250-3.

Quick Start: Programmable single touch button to start a cycle.

ADDITIONAL FUNCTIONS:

Holding: At the end of any cycle, the unit will automatically switch to a holding mode.

Defrost: A heated defrost cycle is included.

Options and Accessories

- Cabinet Sanitation:** The ozone and PhotoPlasma generator sanitizes all metal surfaces within the cabinet in a preset time of 30 minutes.
- USB HACCP Interface:** Use a standard USB thumb drive to easily download HACCP data. The information recorded includes date, time, cycle identification, recipe name, and product core temperature at prescribed intervals.
- Wi-Fi Connectivity:** Supported functions include peer-to-peer connectivity, remote monitoring over the local network, HACCP data download and alarm notifications via e-mail.
- Remote Refrigeration:** RCU4BC, available in air cooled and water cooled configuration (5 year compressor, 1 year parts warranty provided).
- Extra Food Probes:** One probe is standard, up to three additional food probes can be provided.
- Mobile Racks:** Model APR13-26 will accommodate 26 full size steam table pans (12"x20"x2 1/2") or 13 full size sheet pans (18"x26").
- Probe holder for liquids:** The probe support will clip onto the edge of a standard steam table pan.
- Bumper Rail:** 2" wide bumper rail mounted on either side of the unit. the center line of the bumper rail will be located at 36" AFF.
- Alternate refrigerant configuration available**
- Reverse cabinet (RHH)**